

INSTALL INSTRUCTIONS C-TM-EXC

HEAVY DUTY TRAK MOUNT 1999-2007 F-250, 350, 450, & 550 1999-2006 FORD EXCURSION

TOOLS REQUIRED:

Ratcheting wrench
Standard socket set

Metric socket set

HARDWARE:

<u>QTY</u>	<u>DESCRIPTION</u>	<u>PART #</u>
1	Front transmission hump bracket	C-B23
1	Rear transmission hump bracket	C-B34
1	32" Trak mount	C-TM-32E
1	Hardware kit	C-HK

C-TM-EXC ASSEMBLY

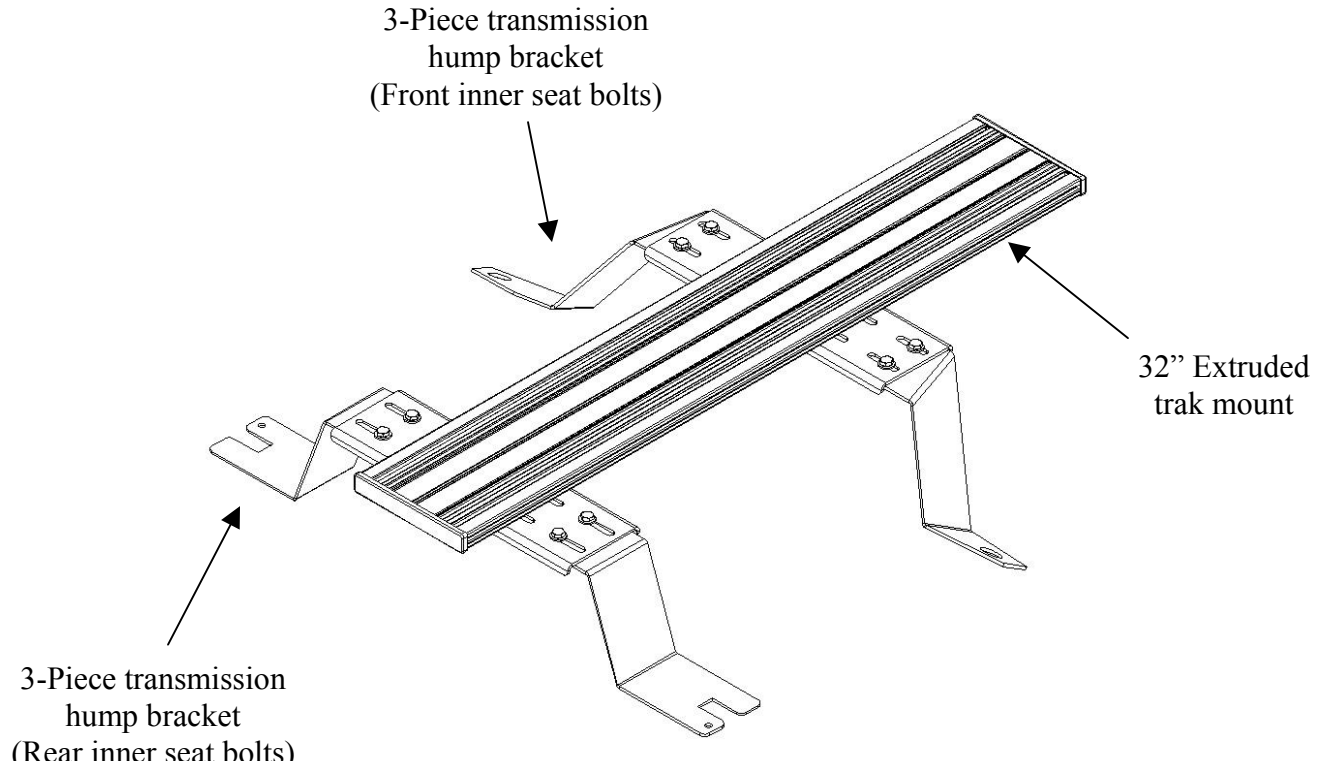

Always!

- Read all instructions before installing any Havis-Shields Equipment Corp products.
- Check for obstructions (Wire, brake lines, fuel tank, etc.) before drilling any holes!
- Use hardware provided with install kit
- For product support, visit the Install Instructions Section of our website at <http://havis.com/Installation/Installation.html>

INSTALLATION:

1. Remove inner front and rear seat-mounting bolts near transmission hump.
Loosen outer bolts only.
2. Place front and rear hump brackets legs in place under seat brackets. Do not bolt down yet.
3. Attach front and rear hump bracket cross piece to Trak extrusion with 1/4" x 3/4" bolts and serrated nuts.
Note: Determine desired cross piece location and tighten hardware prior to attaching to legs.
4. Attach Trak with front and rear crosspiece to hump bracket legs using 1/4" x 3/4" hex bolts and washers.
5. Tighten seat bolts and all hardware.
6. Install nuts in Trak slots as needed and attach console and/or accessories to Trak platform.
7. Attach Trak plastic End caps to Trak. (peel and stick)